



## Axijet-V<sup>®</sup> & KVC<sup>®</sup> High Plume Exhaust

# INSTALLATION, OPERATION, AND MAINTENANCE MANUAL

---

## Introduction

This bulletin has been prepared to guide the users of Axijet-V In-line Mixed Flow & Centrifugal Fans and KVC In-line Centrifugal Fans in the proper installation, operation and maintenance procedures to insure maximum equipment life with trouble-free operation.

## Shipping and Receiving

All M.K. Plastics products are carefully constructed and inspected before shipment to insure the highest standards of quality and performance. Compare all components with the bill of lading or packing list to verify that the proper unit was received. Check each unit for any damage that may have occurred in transit. Any damage should be reported immediately to the carrier and the necessary damage report filed.

## Handling

Handling of all air moving equipment should be conducted by trained personnel and be consistent with safe handling practices. Verify the lift capacity and operating condition of handling equipment. Maintain handling equipment to avoid serious personal injury. Units shipped completely assembled may be lifted with slings and spreader bars. Use well-padded chains, cables or nylon straps. On most units, lifting lugs are fashioned to protect the fan and fan housing from damage (see Figure 1). Never lift a fan by the inlet or discharge flange, shafting or drives, wheel, motor or motor base, or in any other manner that may bend or distort parts. If installation is to be delayed, store the unit in a protected area. Protect the fan and motor bearings from moisture and vibration (or shock loading). For extended storage, wrap entire unit in plastic. Wrap loosely so air may circulate around the fan and moisture does not collect, or use a desiccant. Extended storage requires monthly inspections. Check for corrosion or damage to the unit and for debris within the fan. Rotate the fan wheel a few revolutions. Stop the wheel in a position other than the initial position. Grease the bearings every month with a grease compatible with the grease supplied with the bearings.

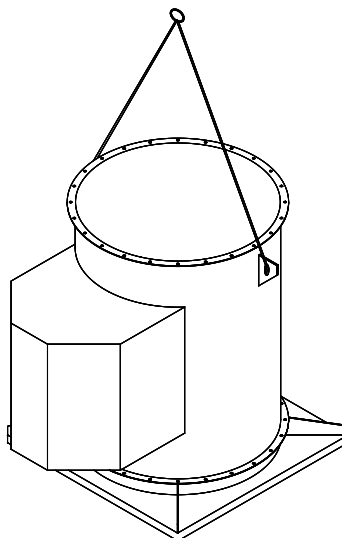

Lifting With Lifting Lugs  
(Standard)

**Figure-1**

## Fan Installation, Factory Assembled Units

Follow proper handling instructions as given earlier.

1. Move the fan to the final mounting position.
2. Remove skid, crates and packing materials carefully.
3. Attach vibration isolators (if used) to appropriate mounting clips on fan. Locate fan in position using lifting instructions above.
4. Carefully level unit using shims (on rigid mounted fans) at mounting hole locations. Fans mounted with vibration isolators may be leveled by adjusting the hardware.
5. Continue with Operations Checklist.

## Motor Maintenance

The three basic rules of motor maintenance are:

1. Keep the motor clean.
2. Keep the motor dry.
3. Keep the motor properly lubricated.

Blow dust off periodically (with low pressure air) to prevent motor from overheating. Some smaller motors are lubricated for life. Lubrication requirements are normally attached to the motor. Use the motor manufacturer's recommendations for relubrication. If this information is not available, the following schedule maybe used. Motors less than 10 HP running about eight hours a day in a clean environment should be lubricated once every five years; motors 15 to 40 HP, every three years. For motors in dusty or dirty environments or running 24 hours a day: divide the service interval by 4. Do not over lubricate.

## Drive Maintenance and Installation

V-belt drives need periodic inspection, retensioning, and occasional belt replacement. When inspecting drives, look for dirt buildup, burrs or obstructions that can cause premature belt or drive replacement. If burrs are found, use fine emery cloth or a stone to remove them. Be careful that dust does not enter the bearings.

Check sheaves for wear. Excessive slippage of belts on sheaves can cause wear and vibration. Replace worn sheaves with new ones. Carefully align sheaves to avoid premature sheave failure.

Inspect the belts for wear. If fraying or other wear is observed to be mostly on one side of the belts, the drives may be misaligned. Reinstall the drives according to the following instructions:

1. Slip (do not pound) proper sheave onto corresponding shaft. CAUTION: Placing fan sheave on motor can over-speed wheel and cause structural failure.
2. Align sheaves with straight edge extended along sheaves, just making contact in two places on outside perimeters of both sheaves.
3. Tighten sheave bolts (or setscrews if appropriate). Table1 can be used to determine the amount of torque required.
4. Install a matched set of belts. Adjust the motor position to obtain slack, install, and tighten belts. Using a pry bar will damage belts.
5. Tighten belts to proper belt tension. Ideal tension is just enough so that the belts do not slip under peak load. When using drive tensioning data supplied by V-belt drive manufacturers, new belts can be tensioned to a value 50% greater than for normal operation. This will reduce retensioning requirements after break-in. Recheck sheave alignment after tensioning.
6. After initial installation of belts, recheck belt tension again after a few days. (New belts require a break-in period of operation.)
7. When replacing belts, replace the entire set. After initial replacement and tensioning, recheck belt tension after a few days. (New belts require a break-in period of operation.) Never use belt dressing on any belts.
8. Fans that have motors and drives mounted at the factory are trim balanced prior to shipment. This is not possible on units that are shipped without motors and drives. The addition of drive components in the field can create unbalance forces. MK Plastics recommends final balancing of the unit after the drive components are installed. Failure to do so may void the warranty.

SIZE	FASTENER			TAPER BUSHINGS		
	GRADE 2	GRADE 5	GRADE 8	BROWNING SPLIT		QD FOR DRIVE
				IN IRON	IN ALUM. HUB	
#10	-	-	-	-	-	5
0.250-20	5.5	8	12	7.9	7.5	9
0.312-18	11	7	25	16	13	15
0.375-16	22	30	45	29	24	30
0.437-14	30	50	70	-	-	-
0.500-13	55	75	110	70	-	60
0.562-12	-	-	-	-	-	75
0.625-11	100	150	220	-	-	135
0.750-10	170	270	380	-	-	-
0.875-9	165	430	600	-	-	-
1-8	250	645	900	-	-	-
1.25-7	500	1120	1500	-	-	-

Tolerance: +5%

For wheel setscrews use Grade 2 values.

The above torque values are for no lubricated fasteners.

**Table-1. Tightening Torque (Ft.-Lbs)**

### Motor Support Adjustment

Two different types of motor mounts, post and saddle, are used on Axijet-V & KVC fans. Which mount to use depends on the size of the fan and motor.

On the post type motor mount, the motor plate is supported on four threaded rods. Belt tension is adjusted by loosening the four nuts on top of the motor plate and raising the motor plate by adjusting the four nuts underneath it. The top nuts should then be tightened to hold the motor plate in place.

On the saddle type motor mount, the motor pivots on one side and adjustment of belt tension is achieved by loosening the nuts on top of the motor plate on the other side, then raising the motor plate by adjusting the nuts underneath the motor plate. The nuts on top of the motor plate should again be tightened to hold the motor plate in place. Several holes are provided on the pivot side, and the pivot point can be raised for gross belt adjustment. If this adjustment is made, however, the motor plate should be as parallel as possible to the fan center plane. Care should be taken to maintain drive alignment and proper belt tension.

### Bearing Maintenance

Proper lubrication of the fan drive bearings helps assure maximum bearing life. All fans are equipped with decals indicating relubrication intervals for normal operating conditions. See Table 2A, 2B and 2C for typical lubrication data. However, every installation is different and the frequency of relubrication should be adjusted accordingly.

Observation of the conditions of the grease expelled from the bearings at the time of relubrication is the best guide as to whether regreasing intervals and amount of grease added should be altered.

Greases are made with different bases. There are synthetic base greases, lithium base, sodium base, etc. Avoid mixing greases with different bases. They could be incompatible and result in rapid deterioration or breakdown of the grease. The lubrication sticker identifies a list of acceptable lubricants. All bearings are filled with a lithium-based grease before leaving the factory. When the fans are started, the bearings may discharge excess grease through the seals for a short period of time. Do not replace the initial discharge because leakage will cease when the excess grease has worked out. Sometimes the bearings have a tendency to run hotter during this period. There is no reason for alarm unless it lasts over 48 hours or gets very hot (over 200°F). When relubricating, use a sufficient amount of grease to purge the seals. Rotate bearings by hand during relubrication.

Relubrication Schedule (Weeks)* Axijet-VM (Class 2)											
Fan Size	Shaft Dia.	Type	Speed [RPM]								
			500	1000	1500	2000	2500	3000	3500	4000	4500
1500	1.187	Ball	12	12	10	6	6	4	4	4	2
1825	1.437	Ball	12	12	10	6	6	4	4	4	2
2225	1.437	Ball	12	12	10	6	6	4	4	4	2
2450	1.687	Ball	12	12	10	6	6	4	4	4	2
2700	1.687	Roller	8	4	3	2	1	1	1	1	1
3000	1.937	Roller	8	4	3	2	1	1	1	1	1
3300	2.187	Roller	8	4	3	2	1	1	1	1	1
3650	2.187	Roller	8	4	3	2	1	1	1	1	1
4025	2.187	Roller	8	4	3	2	1	1	1	1	1
4450	2.437	Roller	6	3	2	1	1	0.5	0.5	0	0
4900	2.437	Roller	6	3	2	1	1	0.5	0.5	0	0
5425	2.687	Roller	6	3	2	1	1	0.5	0.5	0	0

**Table-2A. Relubricating Schedule (Weeks) – Axijet-VM (Class 2)**

Relubrication Schedule (Weeks)* Axijet-VC & KVC (Class 2)											
Fan Size	Shaft Dia.	Type	Speed [RPM]								
			500	1000	1500	2000	2500	3000	3500	4000	4500
1225	1.000	Ball	12	12	10	6	6	4	4	4	2
1500	1.187	Ball	12	12	10	6	6	4	4	4	2
1825	1.437	Ball	12	12	10	6	6	4	4	4	2
2225	1.437	Roller	12	8	8	4	2	2	2	2	1
2450	1.937	Roller	8	4	3	2	1	1	1	1	1
2700	1.937	Roller	8	4	3	2	1	1	1	1	1
3000	2.187	Roller	8	4	3	2	1	1	1	1	1
3300	2.187	Roller	8	4	3	2	1	1	1	1	1
3650	2.187	Roller	8	4	3	2	1	1	1	1	1
4025	2.437	Roller	6	3	2	1	1	0.5	0.5	0	0
4450	2.687	Roller	6	3	2	1	1	0.5	0.5	0	0
4900	2.937	Roller	6	3	2	1	1	0.5	0.5	0	0
5425	3.437	Roller	6	3	2	1	1	0.5	0.5	0	0

**Table-2B. Relubricating Schedule (Weeks) – Axijet-VC & KVC (Class 2)**

Relubrication Schedule (Weeks)* Axijet-VC & KVC (Class 3)											
Fan Size	Shaft Dia.	Type	Speed [RPM]								
			500	1000	1500	2000	2500	3000	3500	4000	4500
1825	1.437	Roller	12	8	8	4	2	2	2	2	1
2225	1.437	Roller	12	8	8	4	2	2	2	2	1
2450	1.937	Roller	8	4	3	2	1	1	1	1	1
2700	2.187	Roller	8	4	3	2	1	1	1	1	1
3000	2.437	Roller	6	3	2	1	1	0.5	0.5	0	0
3300	2.437	Roller	6	3	2	1	1	0.5	0.5	0	0
3650	2.937	Roller	6	3	2	1	1	0.5	0.5	0	0
4025	3.437	Roller	6	3	2	1	1	0.5	0.5	0	0
4450	3.437	Roller	6	3	2	1	1	0.5	0.5	0	0
4900	3.437	Roller	6	3	2	1	1	0.5	0.5	0	0
5425	3.937	Roller	5	2	1	0.5	0	0	0	0	0

**Table-2C. Relubricating Schedule (Weeks) – Axijet-VC & KVC (Class 3)**

\*Suggested lubrication interval under ideal continuous operating conditions. Relubricate while running, if safety permits, until some purging occurs at seals. Adjust lubrication frequency depending on conditions of purged grease. Hours of operation, temperature, and surrounding conditions will affect the relubrication frequency required.

1. Lubricate with a high quality NLGI No. 2 lithium-base grease having rust inhibitors and antioxidant additives, and a minimum oil viscosity of 500 SUS at 100°F (38°C). Some greases having these properties are:
  - a. Shell - Alvania RL
  - b. Exxon - Ronex MP
  - c. Mobil - Mobilith SHC100
  - d. Mobil - Mobilith SHC220
2. Lubricate bearings prior to extended shutdown or storage and rotate shaft monthly to aid corrosion protection.

### Wheel and Shaft Maintenance

Periodically inspect the shaft and wheel for dirt build up, corrosion, and signs of excess stress or fatigue. Clean the components. If the wheel is removed for any reason, make sure that it is securely attached to the shaft before restarting the fan.

### Structural Maintenance

All structural components or devices used to support or attach the fan to a structure should be checked at regular intervals. Vibration isolators, bolts, foundations, etc., are all subject to failure from corrosion, erosion, and other causes. Improper mounting can lead to poor operation characteristics or fan fatigue and failure. Check metallic components for corrosion, cracks, or other signs of stress. Concrete should be checked to insure the structural integrity of the foundation.

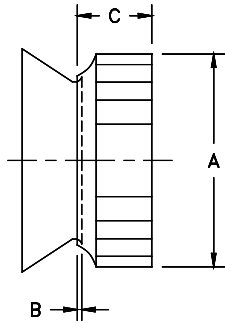

SIZE	1225	1500	1825	2225	2450	2700	3000	3300	3650
A	12.25	15.00	18.25	22.25	24.50	27.00	30.00	33.00	36.50
B	0.31	0.38	0.56	0.69	0.75	0.88	0.97	1.06	0.94
C (CL 1)	4.69	5.86	7.36	8.89	9.86	10.91	11.89	13.31	14.72
C (CL 2)	4.72	5.86	7.42	8.95	9.86	10.91	11.89	13.31	14.72
C (CL 3)	-	-	7.48	9.08	9.92	10.97	12.14	13.38	14.78

SIZE	4025	4450	4900	5425
A	40.25	44.50	49.00	54.25
B	1.03	1.13	1.25	1.38
C (CL 1)	16.23	17.92	19.64	21.70
C (CL 2)	16.23	17.92	19.64	21.70
C (CL 3)	16.30	17.98	19.70	21.83

Note: Use 'B' dimension for positioning wheel.

**Table-3. Wheel-Funnel Overlap (Centrifugal Impellers)**

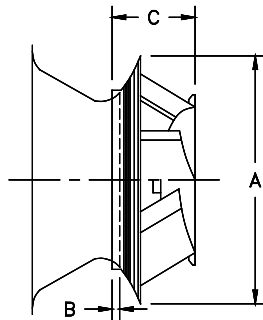

Size	1500	1825	2225	2450	2700	3000	3300	3650
A	18.25	22.25	27	30	33	36.5	40.25	44.5
B	0.56	0.69	0.88	0.97	1.06	0.94	1.03	1.13
C	6.19	7.56	9.13	10.19	11.19	12.38	13.63	15.13

Size	4025	4450	4900	5425
A	49	54.25	60	66
B	1.25	1.38	1.56	1.69
C	16.63	18.38	20.25	22.31

Note: Use 'B' dimension for positioning wheel.

**Table-4. Wheel-Funnel Overlap (Mixed-Flow Impellers)**

NOTE: On KVC fans, the discharge stack is replaced with a velocity cone.

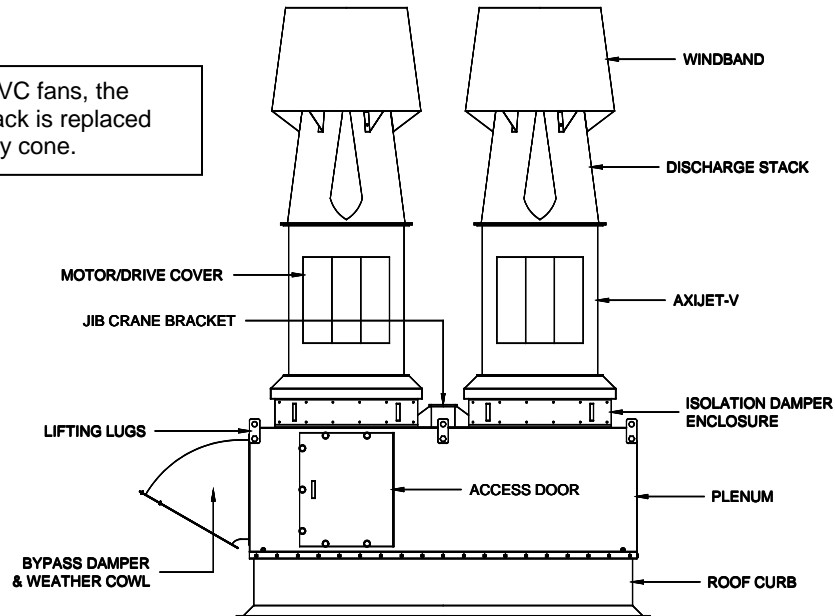

**Figure-2. Axijet-V Fan & Plenum Assembly (KVC - Similar)**

## Axijet-V or KVC Fan & Plenum Assembly Installation

Depending on the size of equipment, the Axijet-V/KVC systems may arrive in module sections due to shipping limitations for job site assembly. Please contact the factory for further details of specific components. Generally speaking, the module sections will consist of the following –

1. Roof curb (by M.K. Plastics or by others).
2. Plenum (may or may not have bypass dampers pre-attached, depending on the plenum size).
3. Fan housing.
4. Stack extension or stack sound attenuator (as an accessory).
5. Discharge stack/windband assembly or velocity cone (may include a transition piece depending on fan size).

Figure-3 & Figure-4 below show a typical method on how to install an Axijet-V/KVC fan or plenum for roof attachment. Please consult structural engineers or architects for particular attachment requirements or methods as specific local codes may apply.

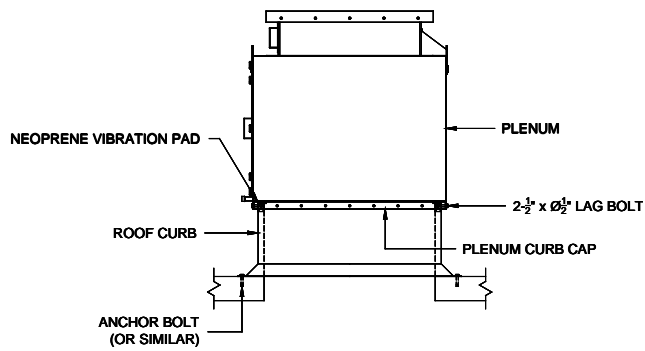

**Figure-3. Plenum to Curb Attachment**

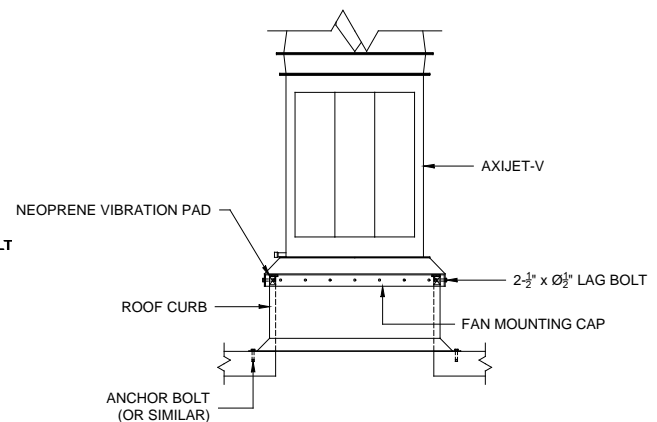

**Figure-4. Axijet-V Fan to Curb Attachment  
(KVC - Similar)**

Assuming the roof curb is in place, refer to Figure-3 & Figure-4 for the following instructions –

1. Check roof curb for levelness as this could affect drainage from plenum and fan(s). Roof should be properly and securely fastened to the roof structure, as per the project construction documents and local building codes.
2. Secure the neoprene vibration pads to the top of the curb wood nailer strip perimeter with either construction adhesive or countersunk self-tapping screws.
3. Lift the plenum onto the curb using a suitable hoist with chains and spreader bar (all plenums will be supplied with lifting lugs), so that the plenum is properly centered on the curb. There should be approximately a 1" gap all around between the inside plenum curb cap and roof curb.
4. If just the fan is being mounted, the mounting cap comes with pre-drilled holes. Drill 5/16" dia. pilot holes through the cap holes into the curb wood nailer strip to about 2" depth.
5. If a plenum is being mounted, pre-drill through the steel curb cap 0.56" dia. holes, and then pilot holes as described above.
6. Secure mounting or curb cap with stainless steel lag bolts. Use anti-seize gel to prevent galling or welding of the fasteners.

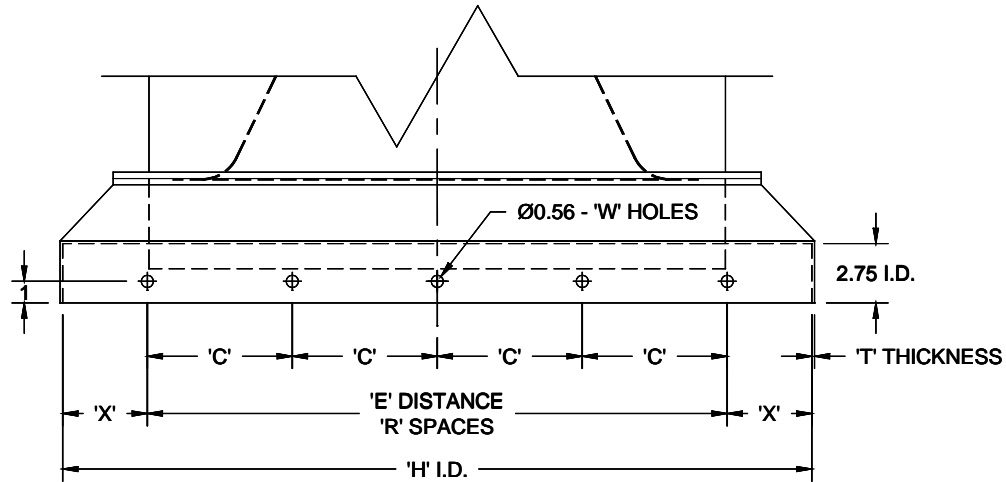

Fan Size	C	E	H	R	W	X	T
122	4.75	19.00	23.75	4	5	2.38	0.13
150	5.00	20.00	27.38	4	5	3.69	0.13
182	6.75	27.00	34.88	4	5	3.94	0.13
222	7.75	31.00	40.38	4	5	4.69	0.18
245	8.50	34.00	43.38	4	5	4.69	0.18
270	9.00	36.00	46.75	4	5	5.38	0.18
300	11.00	44.00	51.00	4	5	3.50	0.18
330	12.00	48.00	55.12	4	5	3.56	0.25
365	13.00	52.00	59.88	4	5	3.94	0.25
402	14.00	56.00	64.88	4	5	4.44	0.25
445	15.50	62.00	69.62	4	5	3.81	0.25
490	8.25	66.00	78.00	8	9	6.00	0.25
542	9.50	76.00	88.75	8	9	6.38	0.25

Table-5. Axijet-V/KVC Mounting Cap Dimensions



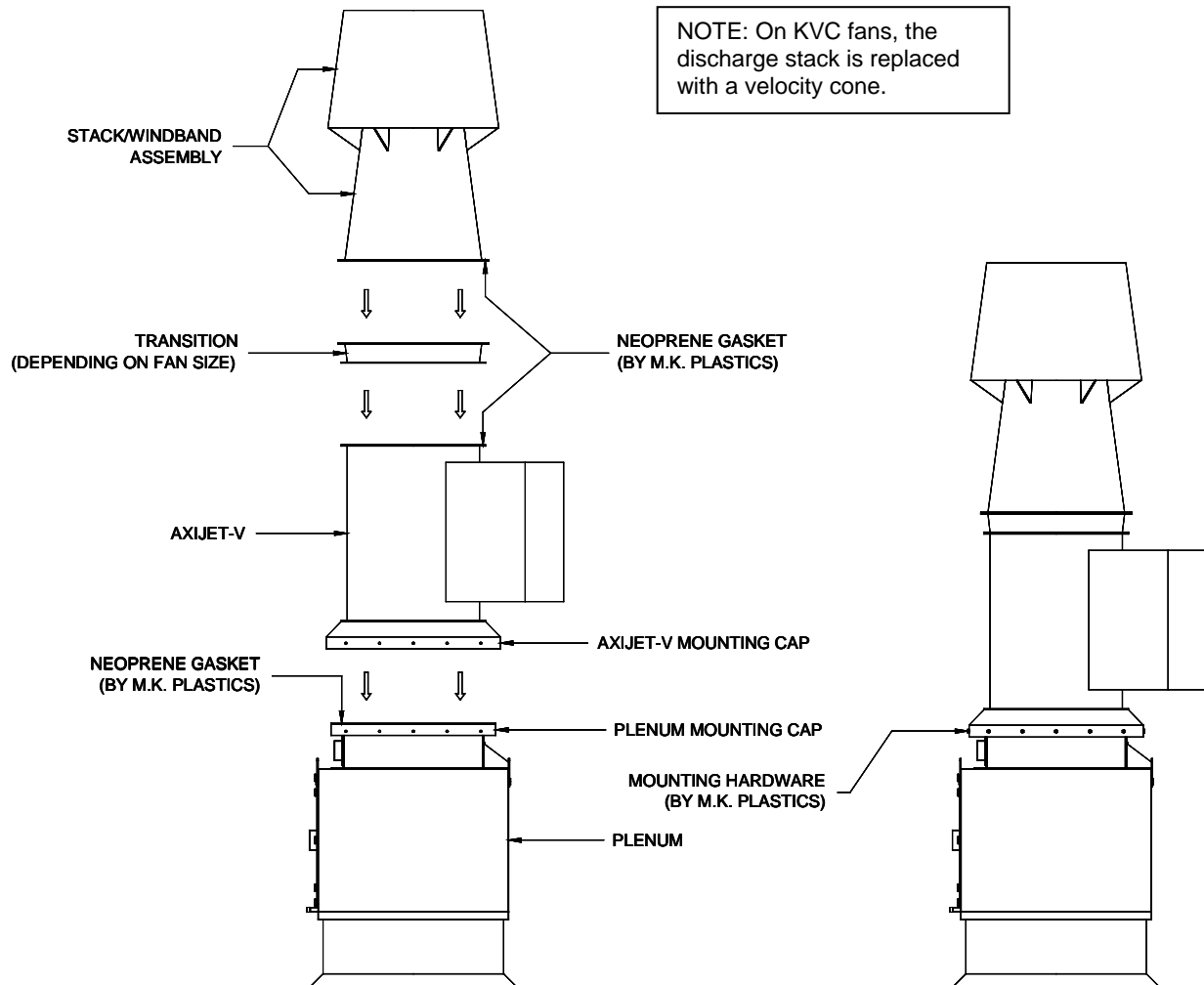

**Figure-5. Axijet-V Fan Installation (KVC – Similar)**

### **Axijet-V/KVC to Plenum Installation**

1. Place the 1" wide x 1/8" thick neoprene gasket along the top of the plenum mounting cap (isolation damper housing).
2. Lower the Axijet-V into place using a suitable hoist and chains. All Axijet-V fans come with lifting lugs.
3. Align the pre-drilled holes in the fan mounting cap and the top plenum mounting cap. Make sure the gasketing is compressed.
4. Secure with stainless steel hardware, provided by M.K. Plastics.

### **Discharge Stack/Windband or Velocity Cone Assembly**

1. Place the 1" wide x 1/8" thick neoprene gasket along the flanges for the fan outlet, transition (if supplied) and stack/cone. The transition may already be attached to the stack, depending on fan size.
2. NOTE: On Axijet-V fans, the discharge stack flange hole pattern is not symmetrical, please align the bolt holes to match those on the fan discharge flange. This allows the bifurcated opening of the stack to line up a certain way.
3. Using a suitable hoist and straps around the outside of the stack bifurcated section, lift the assembly onto the fan outlet flange.
4. Secure with stainless steel hardware, provided by M.K. Plastics.

## Drainage Detail

All Axijet-V/KVC fans and inlet plenums come as standard with outlet drains due to the possibility of water or condensation that may occur. Proper disposal of water must occur by connection of drain outlet to a drainage system (by others). Piping must have adequate pitch for proper runoff and be supported (if needed) to prevent the possibility of sagging and overflow. The trap should be filled before start-up.

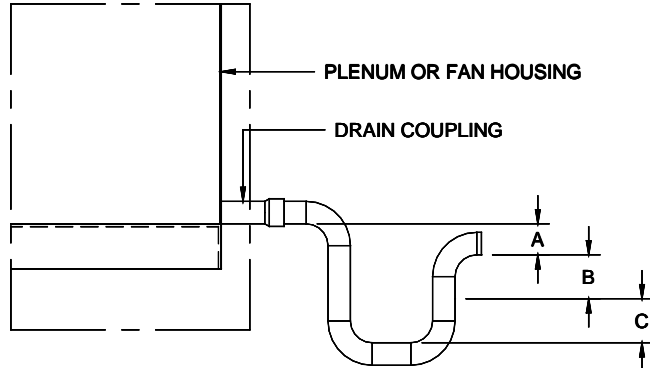

- A. Must be greater than system static pressure, in inches.
- B. Must be greater than 1/2 of the system static pressure, in inches.
- C. 1" water seal.

## Wiring Installation

All wiring should be in accordance with local ordinances and the National Electrical Code, NFPA 70. Ensure the power supply (voltage, frequency, and current carrying capacity of wires) are in accordance with the motor nameplate.

**Lock off all power sources before unit is wired to power source.**

### Personal Safety

Disconnect switches are recommended. Place the disconnect switch near the fan in order that the power can be swiftly cut off in case of an emergency, and in order that maintenance personnel are provided complete control of the power source.

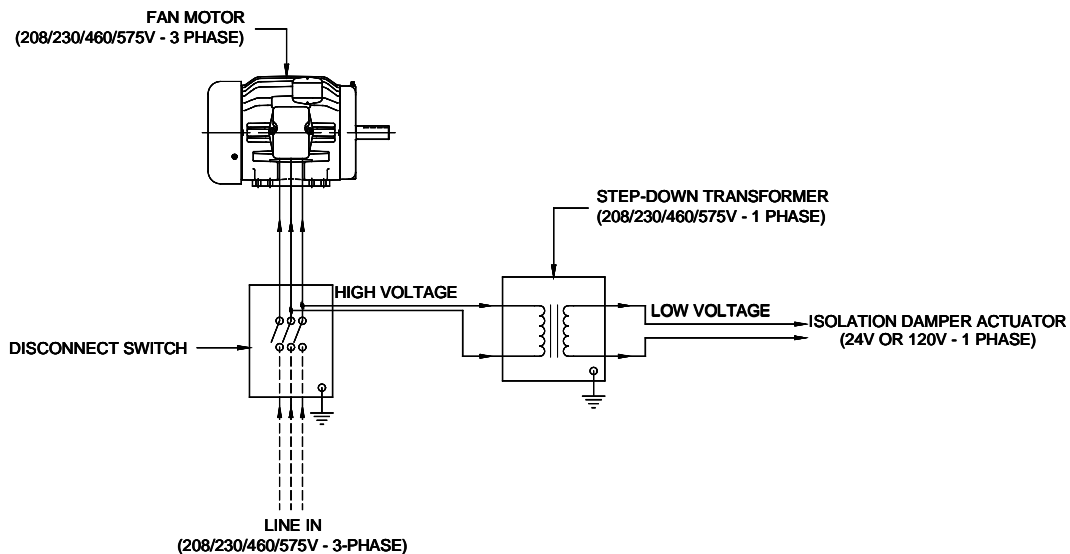
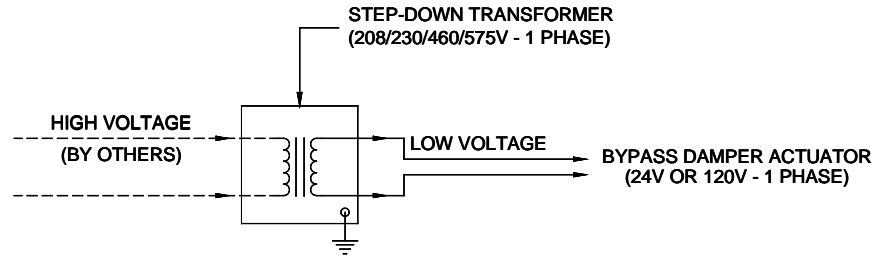

Figure-6. Isolation Damper Wiring Schematic



**Figure-7. Bypass Damper Wiring Schematic**

### Operation Checklist

- Verify that proper safety precautions have been followed.
- Electrical power must be locked off.

#### Check fan mechanism components:

- Nuts, bolts, set screws are tight.
- Mounting connections are properly made and tightened.
- Bearings are properly lubricated.
- Wheel, drives and fan surfaces are clean and tightened.
- Rotating assembly turns freely and does not rub.
- Drives on correct shafts, properly aligned, and properly tensioned.

#### Check fan electrical components:

- Motor is wired for proper supply voltage.
- Motor was properly sized for power of rotating assembly.
- Motor is properly grounded.
- All leads are properly insulated.

#### Trial "bump":

- Turn on power just long enough to start assembly rotating.
- Check rotation for agreement with rotation arrow.
- Listen for any unusual noise.

#### Run unit up to speed:

- Bearing temperatures are acceptable (<200°F) after one to two hours of operation.
- Check for excess levels of vibration. Filter in readings should be 0.15 inches per second or less.

#### After one week of operation:

- Check all nuts, bolts and setscrews and tighten if necessary.
- Readjust drive tension if necessary.

## Troubleshooting

<b>Problem and Potential Cause</b>
<b>Low Capacity or Pressure</b> <ul style="list-style-type: none"><li>• Incorrect direction of rotation. Make sure the fan rotates in same direction as the arrows on the motor or drive belt assembly.</li><li>• Poor fan inlet conditions. There should be a straight clear duct at the inlet.</li><li>• Improper wheel alignment.</li></ul>
<b>Excessive Vibration and Noise</b> <ul style="list-style-type: none"><li>• Damaged or unbalanced wheel.</li><li>• Belts too loose; worn or oily belts.</li><li>• Speed too high.</li><li>• Incorrect direction of rotation. Make sure the fan rotates in same direction as the arrows on the motor or drive belt assembly.</li><li>• Bearings need lubrication or replacement.</li><li>• Fan surge or incorrect inlet condition.</li></ul>
<b>Overheated Motor</b> <ul style="list-style-type: none"><li>• Motor improperly wired.</li><li>• Incorrect direction of rotation. Make sure the fan rotates in same direction as the arrows on the motor or drive belt assembly.</li><li>• Cooling air diverted or blocked.</li><li>• Improper inlet clearance.</li><li>• Incorrect fan RPM.</li><li>• Incorrect voltage.</li></ul>
<b>Overheated Bearings</b> <ul style="list-style-type: none"><li>• Improper bearing lubrication.</li><li>• Excessive belt tension.</li></ul>